



GD10P Series



Overview

The GD10P series of infrared gas detectors has set the standard in the areas of performance, safety, response time, stability and maintenance.

Features

- Solid state IR sources (SimSource™) for superior long term performance compared to filament lamps
- No recalibration, monitors and accounts for all changes in optical path thanks to true dual path, double compensation optical design
- Dual layer weather protector (No mesh, gauze, hydrophobic filters or sinters = No delay, no failure on demand)
- Early dirty optics warning for improved preventative maintenance



GD10P Series

IR Point Gas Detector

GD10P

IR Point Gas Detector



GD10P LEL and CO₂

The GD10P differs from all other infrared gas detectors because it uses a silicon-based solid-state infrared source instead of a filament. The patented Sim-Source™ solid state IR light source is extremely stable. The intensity of the IR light does not deteriorate over time like a filament, therefore the GD10P never requires calibration for compensation of this signal. In addition to the stability, the Sim-Source light has the best longevity in the industry and is covered by a 15-year full replacement warranty.

All optical components are mounted on single metal platform which provides stability of measurements even in high vibration environments. The dual path-length design compensates for temperature, humidity, and particulates in the environment. The heated optics eliminate the adverse effects of moisture in high humidity applications. There are also two user-adjustable levels of dirty optics indications, a warning and alarm. The GD10P is so robust that it will operate and alarm with up to 70% optics signal blockage. Optics can be easily cleaned with a moist cloth and there is no need to declassify the area for this service procedure.

Another area where the GD10P excels is with the ultra-fast response times, responding to gas exposures in only a few seconds. The patented dual layer weather shield design allows gas to rapidly enter and exit the measurement chamber. Since the weather shield contains no sinters or mechanical filters, it provides the same fast response under any conditions: from stormy offshore platforms to wind-swept desert applications. Response times can be adjusted through a HART hand-held.

On-board watch dog circuitry continuously monitors the GD10P's electronics and firmware, providing true fail-safe operation. The sensor performance meets or exceeds CSA and ATEX requirements, and the GD10P circuitry has been test by a third-party (TUV) for use in SIL2 rated systems.

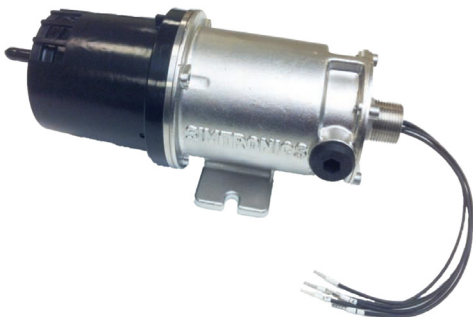

GD10P (UL)

The GD10P LEL detects and measures combustible hydrocarbons in a wide range industrial environments from wastewater treatment plants to oil refineries and offshore oil rigs. The IR sensor technology is immune to the poisoning effects of H₂S and other inhibiting substances. The GD10P (UL) provides all the same benefits as the standard GD10P LEL, but in a UL approved Class I, Division 1 Group B-D rated enclosure with NPT fittings.

Infrared sensors are the most accurate and stable way to measure carbon dioxide in quantities from low ppm to 100% volume CO₂. The GD10P CO₂ is designed for diverse applications including waste digesters and breweries for fast and reliable measurement of this toxic gas.

- An industry standard HART® interface is used for configuration of special faultlevels as well as access to extended maintenance data
- Integral termination compartment for reduced installation time: the unit is ready out of the box
- Low-power consumption which reduces load on UPS
- Independently heated mirror and lens for high performance detection in rough environmental condition
- Suitable for use in SIL 2 and SIL 3 systems

GD10PE

IR Extended Point Gas Detector



Monitoring fresh air intakes for hydrocarbons which feed control rooms, maintenance garages, and other buildings with human occupancy is a necessary safety precaution in facilities like oil refineries and petrochemical plants. The GD10PE is designed for these critical applications involving large volumes of air with high velocity. The extended measuring chamber makes the GD10PE uniquely suitable for the larger area of these HVAC intakes.

The GD10PE is designed to measure hydrocarbons on the enclosure ventilation exhausts of gas turbines and compressors, the only location where you can guarantee to detect a gas leak in these operations. In applications where you need fast reliable detection of low gas concentrations, the GD10PE - with a range of 0-10,000 ppm CH₄ - is five times more sensitive than conventional point detectors.

GD10PE in application

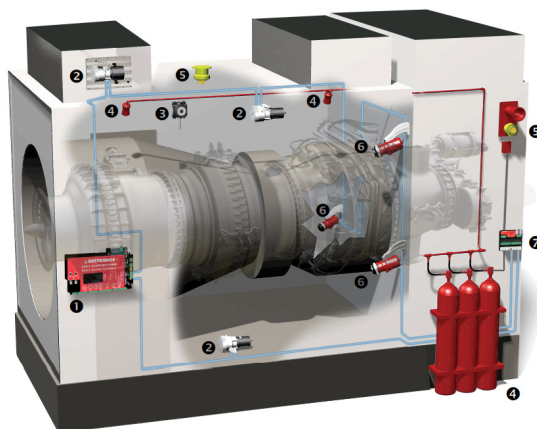
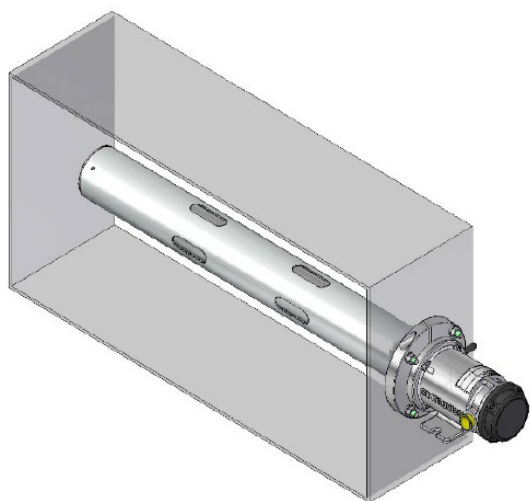

Technical Data

Gas Detector

Detector Technology	IR-adsorption, dual wavelength, dual path
Gases Detected	Hydrocarbons (LEL) and Carbon Dioxide (CO ₂)
IR Emitter Type	Patented solid-state IR source
IR Emitter Life	Expected Life > 20 years
Calibration	Factory set, no field calibration required
System Self-Test	Continuous

Performance

Measuring Range, Hydrocarbons	0-100 %LEL: Methane, Propane, Acetone, Acetylene, Benzene, n-Butane, Cyclohexane, Ethane, Ethanol, Ethylene, Hexane, Methane-Biogas, Methanol, Pentane, Propylene, Styrene, Toulene 0-100 %Vol.: Methane, Propane
Measuring Range, CO ₂	0-10,000 ppm, 0-3.00, 0-5.00 & 0-100 %Vol. CO ₂
Response Times (with weather shield installed)	GD10P, methane: T20 = 0.2 sec / T50 = 0.4 sec / T90 = 1.0 sec GD10P, other hydrocarbons: T20 = 1.0 sec / T50 = 2.5 sec / T90 = 6.0 sec GD10P, carbon dioxide: T20 = 1.0 sec / T50 = 2.5 sec / T90 = 6.0 sec GD10PE, 1 %Vol. LEL CH ₄ : T20 = 0.8 sec / T50 = 2.1 sec / T90 = 5.0 sec
Accuracy	GD10P, hydrocarbons: +/- 3% FS 0-50% reading / +/- 5%FS 50-100% reading GD10P, carbon dioxide: +/- 5% FS 0-50% reading / +/- 7%FS 50-100% reading GD10PE. +/- 1 %LEL 0-10%LEL / +/- 1.4 %LEL 10-20%LEL

Environmental

Operating Temperature	GD10P Transmitter: -40 to +140 F / -40 to +60 C GD10PE In-situ Probe: -40 to +185 F / -40 to +85 C
Storage Temperature	-40 to +158 F / -40 to +70 C
Operating Humidity	0-100 %RH, non-condensing

Electrical

Operating Voltage	24 VDC (18-32 VDC)
Power Consumption	3.5 Watts (without optional display module)
Wire Requirements	3 conductor, shielded, 14-20 AWG (0.5 - 2.5 mm ²)
Maximum Impedance	500 ohms

Signal Output

Analog Signal	4-20 mA current sourcing / Optional current sinking
Digital Signal	HART® 7 for system configuration
Detector Warning Signals	<p>2 mA, early optics warning, 55% optics blockage</p> <p>1 mA, main optics alarm, 70% optics blockage</p> <p>0 mA, System Fault</p> <p>GD10P continues to detect gas and will signal 10 %LEL while in main optics alarm condition</p> <p>Optics alarm levels adjustable via HART handheld</p>

Approvals

ATEX / IECEx / INMETRO	II 2 G / Ex db eb IIC T6 Gb
CSA	<p>C22.2 No 152-M984 and ANSI 12.13.01-2000</p> <p>Ex d e IIC T6 (Canada only)</p> <p>Class 1, Division 2, Groups A-D (US and Canada)</p>
UL version	Class 1, Division 1, Groups A-D (US only)
SIL	SIL 2 Certified (software SIL 3) by TUV
EMC	Compliant to EN 50270

Enclosure

Transmitter Construction	316 Stainless-steel (SIS2343)
Weather Shield Construction	ABS Plastic
Ingress Protection	IP-66 / IP-67
Cable Entries	<p>(2) M20 male (CSA & ATEX versions)</p> <p>(1) 3/4 NPT (UL version)</p>

Physical

Dimensions, L x W x H	<p>GD10P: 10.4 x 4.1 x 4.2 in (264 x 104 x 106 mm)</p> <p>GD10PE: 31.7 x 4.1 x 4.2 in (805 x 104 x 106 mm)</p>
Weight	<p>GD10P: 6.4 lbs (2.9 kg)</p> <p>GD10PE: 14.3 lbs (6.5 kg)</p>

Warranty

Transmitter	5 years
IR Emitter	15 years

GD10P Series

IR Point Gas Detector

GD10P Display & Relay Module

Display Module



The Display Module is a universal gas detector display for Teledyne Gas and Flame Detection devices with a 4-20 mA output. The high-resolution LCD display has three alternative display screens. The first screen shows the current measured concentration, target gas and engineering units. The second screen also has a concentration bar graph with alarm set points, as well as an alphanumeric location ID. On the third alternative screen, the display can show a trend graph of the most recent 30-minute history.

Alarm conditions are indicated by the backlight changing color. Plain text messages also indicate "Alarm 1", "Alarm 2", "Fault" or other status. Optional on-board relays can signal two concentration alarms and a fault condition.

Housed in a rugged weather-proof and explosion-proof aluminum or stainless-steel housing, this display module can be mounted directly to the gas detector or remotely in an area that is more conducive for viewing the display. All display module functions can be operated in a hazardous area using a magnetic wand to access the non-intrusive controls.

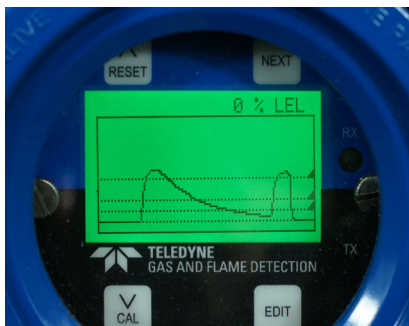

System OK



Warning



Alarm

Specifications

Power Supply	10-30 VDC at < 6.5 watts with relay board (all relays energized)
Display	2.1" x 1.2" (54x31 mm) 128x64 pixel color backlit LCD display
Standard Output	3-wire 4-20mA current source. Max loop Resistance 600 ohms @ 24VDC
Optional Outputs	Two programmable concentration relays plus dedicated Fault relay Form C (SPDT) 5A @ 240VAC Resistive load
Operating Temperature	-40°C to +60°C
Housing	Aluminum with epoxy paint (standard) #316 stainless steel(optional)
Dimensions	Width 5.7" (145 mm), Height 5.0" (126 mm), Depth 4.25" (108 mm)
Shipping Weight	6.5 pounds (3 kg) Aluminum 9.5 pounds (4 kg) Stainless Steel
Hazardous Area Rating	CSA Certification for Class 1, Div. 1 and Class 1 Div. 2 locations (T4)

Order Information

All GD10P are provided with a 316 stainless steel enclosure, weather shield, 4-20 mA signal output, HART communications, two M20 cable entries, and SIL2 certification. Instrument Warranty, 5 years. Sim-Source IR emitter warranty, 15 years.

GD10P LEL	Part Number
GD10P LEL, Methane calibration, 0-100 %LEL, c.CSA.us approved Class I, Division 2, Groups A-D	GD10-P00-17DG-0BH-00
GD10P LEL, Propane calibration, 0-100 %LEL, c.CSA.us approved Class I, Division 2, Groups A-D	GD10-P00-09DG-0BH-00
GD10P LEL, Methane calibration, 0-100 %Vol., c.CSA.us approved Class I, Division 2, Groups A-D	GD10-P00-17BG-0BH-00

GD10P UL	Part Number
GD10P LEL, Methane calibration, 0-100 %LEL, UL approved Class I, Division 1, Groups B-D	TBD
GD10P LEL, Propane calibration, 0-100 %LEL, UL approved Class I, Division 1, Groups B-D	TBD

GD10P CO ₂	Part Number
GD10P CO ₂ , Carbon Dioxide, 0-5.0 %Vol., c.CSA.us approved Class I, Division 2, Groups A-D	GD10-P00-23BH-0BH-00
GD10P CO ₂ , Carbon Dioxide, 0-5.0 %Vol., c.CSA.us approved Class I, Division 2, Groups A-D	GD10-P00-24BG-0BH-00

GD10P PE	Part Number
GD10PE, Methane calibration, 0-20 %LEL, c.CSA.us approved Class I, Division 2, Groups A-D	GD10-PE0-17DG-0BH-00

*ATEX approved versions available, contact Teledyne Gas & Flame for details
Calibrations for other hydrocarbons available, contact Teledyne Gas & Flame for details*

Accessories	Part Number
Display Module, Aluminum Enclosure, c.CSA.us approved Class I, Division 1, Groups A-D	R-5000AL-2
Display & Relay Module, Aluminum Enclosure, c.CSA.us approved Class I, Division 1, Groups A-D	R-5000AL-2
Display Module, Stainless Steel Enclosure, c.CSA.us approved Class I, Division 1, Groups A-D	R-5000AL-2
Display & Relay Module, Stainless Steel Enclosure, c.CSA.us approved Class I, Division 1, Groups A-D	R-5000AL-2
M20 male to 3/4 NPT female adaptor, nickel plated brass	899-M20075-BNP
M20 male to 3/4 NPT female adaptor, stainless steel	899-M20075-MSS
Sun Shade, horizontal mounting, GD10P & GD10PE	499-815712
Weather Protection, GD10PE	499-815430
Insect Screen (stainless steel mesh inlet cover), GD10P	499-813397
Flow-Thru Measurement Chamber, for in-line measurements, GD10P	AS034-X
Horizontal Pipe Mount Kit with adaptor plate, fits 2" pipe, GD10P	499-816867
Duct Mount Kit, GD10P	499-811938
Duct Mount Kit, GD10PE	499-815271
Bump Test Sleeve, Leather, GD10P	599-818154



TELEDYNE

GAS AND FLAME DETECTION

Everywhereyoulook™



AMERICAS

14880 Skinner Rd
Cypress, TX 77429
USA
Tel.: +1 713-559-9200
Fax: +1 281-746-3064

EMEA

ZI Est, Rue Orfila,
CS 20417
62027 ARRAS CEDEX, France
Tel.: +33-3-21-60-80-80
Fax: +33-3-21-60-80-00

ASIA PACIFIC

Room 04, 9th Floor
275 Ruiping Road
Xuhui District, Shanghai,
China
TGFD_APAC@teledyne.com

www.teledynegasandflamedetection.com

